

PAPER NAME

**Cando unimal.docx**

---

WORD COUNT

**3201 Words**

CHARACTER COUNT

**16804 Characters**

PAGE COUNT

**7 Pages**

FILE SIZE

**1.2MB**

SUBMISSION DATE

**Mar 8, 2023 11:19 AM GMT+7**

REPORT DATE

**Mar 8, 2023 11:19 AM GMT+7**

---

**● 8% Overall Similarity**

The combined total of all matches, including overlapping sources, for each database.

- 6% Internet database
- 5% Publications database
- Crossref database
- Crossref Posted Content database
- 4% Submitted Works database

**● Excluded from Similarity Report**

- Bibliographic material
- Quoted material

# THE INFLUENCE OF HOT POINT ON MTU CB CONDITION AT THE PGELI-GIUGUR 1 BAY LINE (PT. PLN PAYA GELI SUBSTATION)

Dina Maizana<sup>1</sup> Cando Situmorang<sup>2</sup> Habib Satria<sup>3</sup> Yanawati Binti Yahya<sup>4</sup>

<sup>1</sup>Electrical Engineering, Universitas Medan Area, Jl. Kolam. No. 1, Medan, 20223, Indonesia, maizanadina@gmail.com

<sup>2</sup>Electrical Engineering, Universitas Medan Area, Jl. Kolam. No. 1, Medan, 20223, Indonesia, candositumorang73@gmail.com

<sup>3</sup>Electrical Engineering, Universitas Medan Area, Jl. Kolam. No. 1, Medan, 20223, Indonesia, habib.satria@staff.uma.ac.id

<sup>4</sup>Electrical Engineering Section, British Malaysian Institute, Universiti Kuala Lumpur, 53100 Gombak, Selangor Malaysia  
Yanawati@unikl.edu.my

✉Corresponding Author: maizanadina@gmail.com | Phone: +6281362987385

## Abstract

Local heating that occurs in substation equipment is caused by the current flowing in the conductor due to resistance. The parts that often experience heating are the terminals and connections at the substation, especially between two different metals, as well as the conductor cross-section which decreases due to corrosion. So that part must be considered. As for how to control or check the temperature is done by using thermovision. The heat temperature of the Circuit Breaker (CB) equipment at the Bay line PGELI-GIUGUR1 at Paya Geli Substation is still in normal conditions where the temperature ranges from 20°C -43°C. But one phase need attention if temperature more than 70°C, it is needed for improvement plans. The temperature difference between the phases of the CB equipment at Bay line P.GELI-GLUGUR 1 at Paya Geli Substation has reached condition 5 (five), so it needs serious attention and a repair plan, to avoid short circuits between phases (R,S,T).

**Keywords:** Substations, thermovision, CB, hotpoints.

## Introduction

PT PLN is one of the most important electricity companies in Indonesia, both by entrepreneurs and the general public. Along with the development of the digital era in the latest views printed on electrical equipment, PT. PLN is already using digital equipment at substations (GI). This digital equipment is used to predict various conditions that occur in electrical equipment, including the temperature at the Circuit Breaker. [Y. Wibisana; R. Setyo Wibowo; I. Arifianto, 2012]

In operation, when the substation equipment conducts electric current, there will be hot temperatures after the current flows in the conductor caused by resistance at the substation itself. Close or side by side cause frequent friction so that it will be prone to heat. The parts that often face heating are the clamps and conductors at the substation, because they are 2 (two) different metals, and the conductor cross-section which decreases due to corrosion. [MT Kesim, H Yu, Y Sun, M Aindow, SP Alpay, 2018] As a result, the part that needs to be considered is how to control it. The digital equipment used to control the heat value is thermovision. In this case the control of the heat value is very important to investigate, because if it is not controlled a short circuit will occur. [EPA Van Lanen, M Popov, 2005] In this study to identify the atmosphere of the heat value in the Bay Glugur 1 equipment using thermovision with the analysis method of the results of the assessment of the phase temperature difference ( $\Delta$ ) based on the MTS-1997 NETA Standard. Measurements were carried out on the conductor section and the clamp section in the bay line.

Several researchers have conducted research on CB using thermovision [T Daszczyński, W Chmielak, 2020] to analysis thermal condition.

So the objective of this paper is an analysis of CB MTU condition equipment using thermovision on the Pgeli-Glugur 1 bay line at PT. PLN Paya Geli substation. With the help of a thermovision device, the temperature on the intended conductor and clamp will be read. From the results of the readings, the value of the temperature difference will be analyzed to see the condition of the equipment based on the 1977 NETA MTS standard.

## Literature Review

The substation is a sub-system of the electrical energy distribution (transmission) system or is an integral part of the distribution system. The transmission line is a sub-system of electrical energy. Substations have electric power

installation facilities consisting of electric power equipment that functions to: transform electric power at different points of gravity, measurement, control of operations and safety of the electrical energy system, arrangement of heavy services to substations (switchyard ) others, and telecommunications equipment. [Liang Jian; Liu Shuxin; Sun Zhuo; Liu Shuze, 2022]

Circuit Breaker according to IEEE C37. 100: 1992 (Standard definitions for power switchgear) is a mechanical switch, which is capable of closing, carrying and breaking heavy currents under normal conditions according to its rating as well as being able to close, carry (within a certain length of time) and stop heavy currents under special abnormal conditions or obstacles according to the rating. The power circuit breaker at a substation is an automatic device that is able to stop closing layers in all conditions, namely a condition of obstacles or natural conditions, or can also act as a tool needed to regulate the electrical energy network by opening a circuit by closing the circuit (acts like a switch). ) by carrying weight with manual or automatic novel control methods, conversely when in an obstacle situation or an unnatural situation the CB can open with the pressure of a recognizing relay, as a result the obstacles can be separated.

In every electrical equipment, most of it has electrical conductivity properties or is able to conduct electricity because it is made of metal. If the equipment is electrified, then the equipment will certainly produce heat. Hot temperatures that exceed the tolerance limit when the tool is operating are a nuisance or abnormality for the tool. This can cause other damage if not handled immediately. [Schiopu Paul; Aurelian Costea, 2017] To prevent this, one of them is to carry out periodic checks and maintenance, namely by observing the temperature of the components using a Thermal Camera. [Pedro J. Zarco-Periñán, José L. Martínez-Ramos, Fco. Javier Zarco-Soto, 2021], [ A.S. Nazmul Huda, Soib Taib, 2013]

Thermovision is an observation by visual means or by using an infrared device using a thermal imager / thermal camera which is then captured and displayed on a screen. Thermovision is used to monitor the temperature of connectors and equipment in the switchyard as an initial justification for detecting hot point anomalies. [MS Wijaya, IMY Negara, 2022], [M Hrabčík, R Goño, S Rusek, 2014 ]

Hot points that occur at joints cause significant temperature differences and are caused by several factors such as not tight bolts, material quality, material life time, dirty clamps. [Pedro J. Zarco-Periñán, José L. Martínez-Ramos, 2018], [JE Smith, G Paoletti, I Blokhintsev, 2004]

These hot points occur at every connection between clamps and conductors or between 2 (two) different materials, usually the type of conductor used by PT. PLN is made from AAAC (All Aluminum Alloy Conductor) [Jakubiak, E. A., and J. S. Matrusz, 1989] while the clamps are made from Aluminum with the causes described above. These hotspot measurements are carried out in a 2-week period but are often also carried out by substation operators at every peak load. Hot spot measurement is also most effective at high loads. [D Siegel, M Anheuser, 2014] PT. PLN differs for each region, if in industrial areas the highest load is during the day when the factories are working and need electricity for their operations, but if in densely populated areas the highest load is usually at night.

### Materials & Methods

The Thermovision tool check is used to look at the connection points in the installation, namely conductors and clamps. Which Thermovision tool will read temperature measurements with Thermography with the help of infrared light and a thermal imager tool that is displayed on a display that always gives reading values from measured points. Thermovision tool as shown in Figure 1.



Figure 1. The Thermovision tool type of FIIR E64501 and series 5306A

The application of thermovision measurements is carried out at the MTU equipment point on the Paya Geli-Giugur 1 CB conductor, sourced from the Single Line Diagram (SID) of the Paya Geli substation as seen in Figure 2. In accordance to the maintenance guidelines in the Decree of the Board of Directors for Maintenance with PIN No 0520-2.K/DIR/2014, then the thermovision measuring points on the MTU CB conductor bay equipment are shown in Figure 3.

Based on IEV (International Electrotechnical Vocabulary) 441-14-20 it is said that a Circuit Breaker (CB) or Energy Breaker is a mechanical switch or switching device, which is capable of closing, flowing and stopping heavy currents in a natural state and is able to close, drain (in a long duration) and stop heavy currents in an abnormal situation or an obstacle similar to a short circuit. In contrast the meaning of PMT originates in IEEE C37. 100: 1992 (Standard definitions for power switchgear) is mechanical switching or switching equipment, which is capable of closing, carrying and

stopping heavy currents in a natural state according to its rating and is capable of closing, flowing (in long duration spans) and stopping heavy currents in special conditions unreasonable or obstacles in accordance with the rating[ ]. This can be seen in Figure 4.

DIAGRAM SATU GARIS GARDU INDUK PAYA GELI

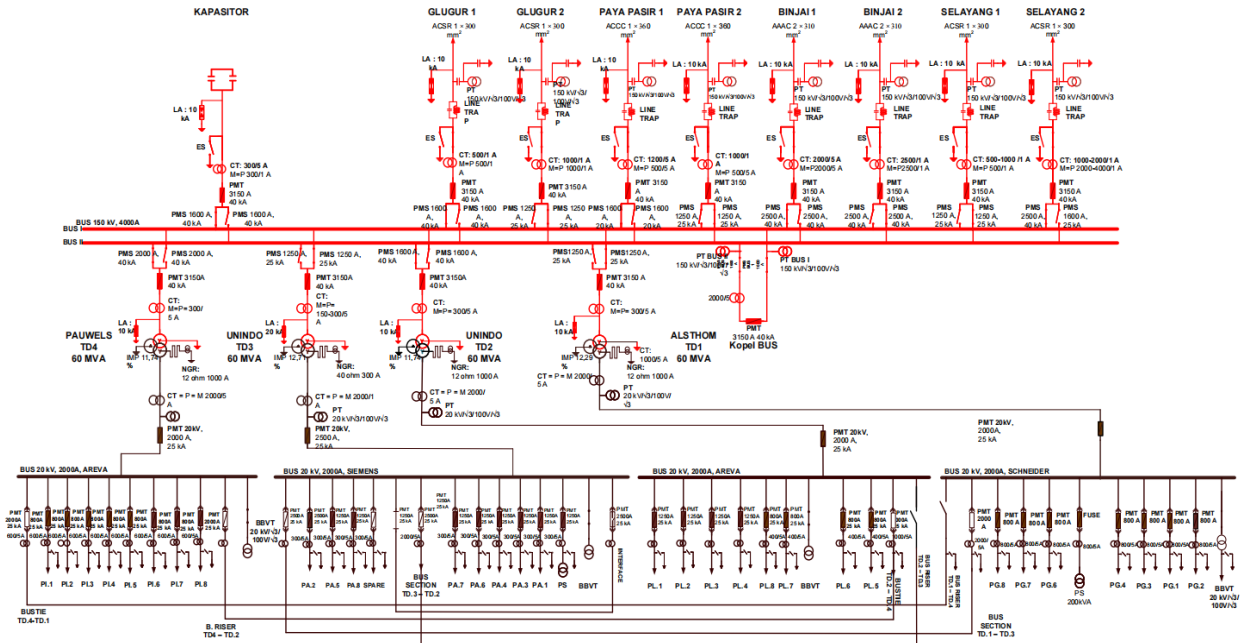

Figure 2. One-line diagram of the Paya Geli Glugur-1 Substation

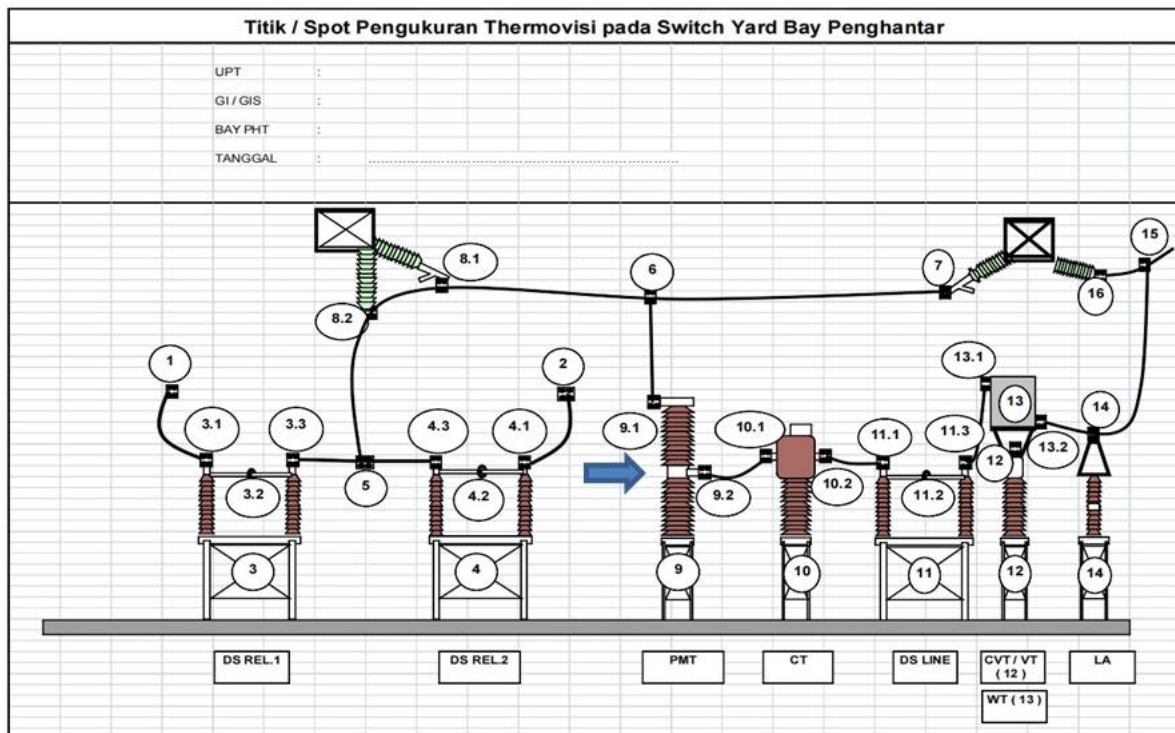

Figure 3. One Bay Conductor

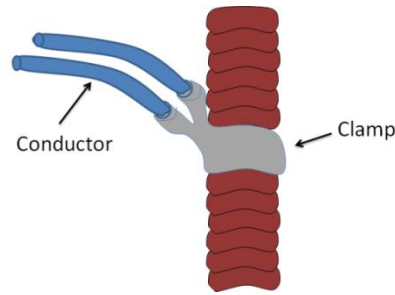

Figure 4. Clamps and Conductors

Table 1. 1977 NETA-MTS Standard

Category	Measurement ( $\Delta t$ )	Condition
1	<10°C	Normal condition, measurement (once a month)
2	10°C -25°C	It is necessary to measure one more month
3	25°C -40°C	Need to plan repairs
4	40°C -70°C	Need to be repaired immediately
5	>70°C	Emergency conditions must be corrected

The equation used to determine the temperature difference between the clamp and the conductor ( $\Delta T$ ) is by using equation (1).

$$\Delta T = \left(\frac{I_{max}}{I_{Ther}}\right)^2 (T_{Clam} - T_{Cond}) \dots\dots(1)$$

Where

- $\Delta T$  = temperature difference between clamp and conductor
- $I_{max}$  = maximum current
- $I_{Ther}$  = Current at thermovision
- $T_{Clam}$  = Clamp temperature
- $T_{Cond}$  = Conductor temperature

Equation 2 is used to calculate the emissivity value (e).

$$P = e \cdot \sigma \cdot T^4$$

$$e = \frac{P}{e \cdot \sigma \cdot T^4} \dots\dots(2)$$

Where

- $P$  = energy thermal conductivity (Aluminum = 23 W/m.K)
- $e$  = emissivity (=1)
- $\sigma$  = Stefan Boltzman constant =  $5.672 \times 10^{-8}$  Watt  $m^{-2}K^{-4}$
- $T$  = Absolute Temperature (K)

To determine the value of the precision test is done by calculating the standard deviation (SD) and the coefficient of variation (cv) using equations 3 and 4.

$$SD = \sqrt{\sum \frac{(x-a)^2}{n-1}} \dots\dots(3)$$

Where

- $n$  = amount
- $a$  = average emissivity value
- $x$  = total emissivity value
- $cv = \left(\frac{SD}{\alpha}\right) \times 100\% \dots\dots(4)$

To determine the accuracy test can be done using equation 5.

$$\% Recovery\ value = \left(\frac{a - x_{real}}{x_{real}}\right) \dots\dots(5)$$

Where

- $x_{real}$  = actual value

### Results and Discussion

The measurement results used the thermovisi brand FIIR E06 on the Bay line PGELI-GIUGUR1 Paya Geli Substation on October 1 2021 at 20.00 WIB (peak load).

From table 2, CB 9.2 Downward Pole towards CT phase R, S, T The highest current that has ever been obtained by a thermovision equipment brand FIIR E06 is 226 A, the current when shooting is 174 A, while the highest clamp temperature when shooting is 87.1°C in phase R the lowest temperature is 32.2°C in phase S, and the highest conductor temperature when shooting is 29.7°C in phase R while the lowest temperature is 28.0°C is read in phase T.

TABLE 2. Results of The Glugur Paya GELI 1

Object	Phase	Highest Current ever achieved	Current during Shooting	Clamp temperature during Shooting	Konductor temperature during Shooting
		$I_{m^2}$ (A)	$I_{s^2}$ (A)	$T_{kls}$ (°C)	$T_{kls}$ (°C)
		A	B		C
1 CB/9.2 Downward Pole CT	R	226	174	87,1	29,7
	S	226	174	32,2	29,6
	T	226	174	33,9	28,0

From Figure 5 it proves the phases R, S, T shooting of clamp material taken through a thermoving device at peak load. From the results of the thermovision reading, it was found that the highest temperature reached 87.1 °C occurred in Phase R. While the lowest temperature was 31.2 °C and it was read in Phase S. For Phase T, the temperature that was read through thermovision was 33.9 °C. So, the comparison of temperature readings between the R phase and the S or T phase is very large, respectively 55.9°C and 53.2°C.

Meanwhile, from Figure 6 when shooting the conductor at peak load with FIIR E06 equipment, it shows different temperature values. From the results of temperature shooting on the R, S and T phase conductors, it is shown that the highest temperature is 29.7°C in the R phase and the lowest temperature is 28.0°C in the T phase while in the S phase it reaches 29.6°C. Hence, the difference in temperature readings on the conductors of each phase is very little, more or less 1.7°C.

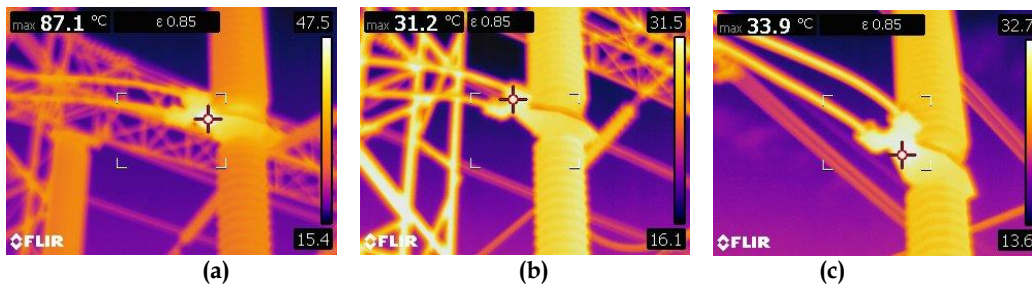

Figure 5. R, S, T phase clamps  
 (a). Lower pole clamp CT direction Phase R  
 (b). S-phase CT clamp the lower pole  
 (c). Lower pole clamp CT direction Phase T

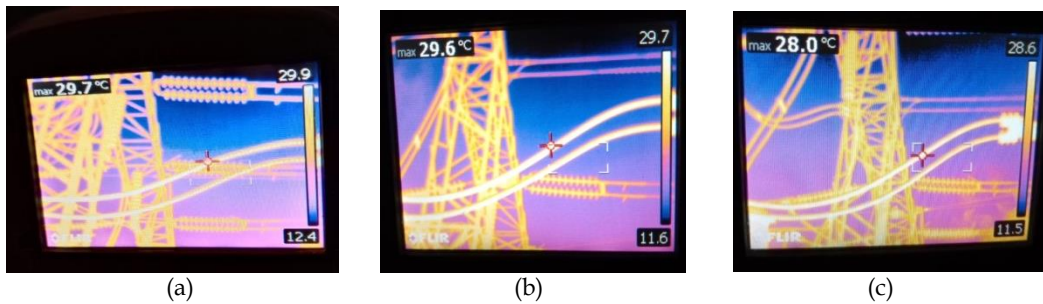

Figure 6. Thermovision of R, S, T phase conductors  
 (a). Down pole conductor CT direction Phase R  
 (b). S-phase CT down pole conductor  
 (c). Conductor down pole CT direction Phase T

To see the temperature difference between the clamp and the conductor, it is shown in table 3. The difference calculation is carried out using equation 1. The calculation results show that the temperature difference in Phase R produces the highest difference, namely 96.83°C and the lowest in Phase S, which is 2.69°C. The object being examined is CB/9.2 Downward Pole in the CT direction.

To see the value of the emitted emissivity can be seen in table 4. The calculation is done using equation 2. From the calculation results the highest emissivity value is in Phase T which is equal to 0.4694. The average value of emissivity is 0.402. Based on the calculation results of the emissivity values that have been summed up, it has a temperature range that is in accordance with the Standard Reference Material (SRM), which is below the emissivity value of aluminum 0.5. [

To determine the value of the precision test can be done using equations 3 and 4. And the calculation results are shown in table 5. The standard deviation results obtained are 0.0754558. For that shows the percentage of calculation errors is 7.6%. While the results of the calculation of the coefficient variation of 1.5, it means that the accuracy of the reading is still considered good.

TABLE 3. Results of Calculation of Thermovision of Glugur Paya Geli 1 Delivery Bay

Object	Phase	Temperature difference between clamps and conductors
		$\Delta T$ (°C)
1 CB/9.2 Downward Pole CT	R	96,83°C
	S	2,69°C
	T	9,95°C

TABLE 4. Calculation Results of Emissivity Values

No	Object	Phase	Clamp temperature during Filming	Emissivity Value
1	CB/9.2 Downward Pole CT	R	87,1	0,2483
2		S	31,2	0,4883
3		T	33,9	0,4694
Average				0,402

TABLE 5. Precision Test Calculation Results

No	Name	Phase	x	$\alpha$	(x - $\alpha$ )	(x - $\alpha$ ) <sup>2</sup>
1	CB/9.2 Downward Pole CT	R	0,2483	0,402	-0,1533	-0,02350089
		S	0,4883	0,402	0,0867	0,00751689
		T	0,4694	0,402	0,0678	0,00459684
$\sum(x - \alpha)^2$					-0,01138716	
SD = $\sqrt{\frac{\sum(x - \alpha)^2}{n-1}}$					0,0754558	
CV = $(\frac{SD}{\alpha}) \times 100\%$					1,5	

In order to validate the calculation in addition to the precision test, it is also necessary to carry out an accuracy test. Equations 4 and 5 are used in the calculation of precision tests and accuracy tests. From the results of the precision and accuracy test calculations are shown in table 6. The accuracy test value reaches 80.4%, meaning that the results of calculating the temperature difference between the clamp and the conductor are quite accurate. And from the precision test of 1.5%, it shows that the temperature difference is quite correct. So, the results of all calculations are quite valid.

Referring to the PIN Maintenance standard No 0520-2.K/DIR/2014 in table 1 and the measurement results and thermovision calculations in Paya Geli-Glugur 1 bay which are listed in table 7, we can make a recommendation for each measuring point condition. In accordance with legal standards, as a result, for equipment listed in condition 1, recommendations for further action will be submitted, in the form of trying a 1-week orderly test of the same type, usually because the material condition does not affect activity, as well as equipment that is in condition 2, see during maintenance, there is also equipment that enters into a situation 5 In a situation where the recommendation for further action is a dangerous situation for this situation, it is necessary to submit a quick agenda so that recommendations can be tried by the maintenance group (HAR), so that the abnormal condition does not get worse and as a result the reliability of electric power distribution can be well maintained.

TABLE 6 Tables of Accuracy and Precision of The Paya Geli-Glugur 1 Delivery Bay.

No	Name	Accuracy (%)	Precision (%)
1	The Paya Geli-Glugur 1 delivery bay	80,4	1,5

**TABLE 7** Recommendations for Follow-Up of Thermovision Measurement Results

NO	Object		Temperature difference between clamps and conductors ( $\Delta T$ )	Condition	Follow-up recommendations
1	CB/9.2 Downward Pole CT	R	96,83°C	5	Emergency Conditions
		S	2,69°C	1	Good condition
		T	9,95°C	2	Check during Maintenance

### Conclusions

From the results of the analysis in the previous section it was found that with a high temperature difference between the clamp and the conductor which exceeds 70°C from the NETA MTS 1977 standard, serious attention is needed. It is because to avoid the possibility of a short circuit.

### Acknowledgments

Thank you very much to the author's parents who have given support and motivation. Then thanks to the lecturer of electrical program study in Universitas Medan Area who has guided and assisted in the completion of this scientific paper.

### References

- Jakubiak, E. A., and J. S. Matrusz. (1989), *High temperature tests of ACSR conductor hardware*. Vol. 4, Issues 1, pg. 524-531, IEEE Transactions on Power Delivery.
- IEC 62271 - 100 edition 1.1: 2003-05, *High-Voltage switchgear and control gear-part 100: High-Voltage alternating-current circuit-breakers*, 2003.
- IEE C37.10-1995, *Guide for diagnostics and failure investigation of power circuit breaker*, 1995.
- The International Electrical Testing Association (NETA) - NETA MTS-1997, *Maintenance Testing Specification*, 1997.
- The Thermovision camera book manual, merk FIIR.
- MS Wijaya, IMY Negara, (2022), *High voltage circuit breaker contact resistance assessment with synchronization test using failure mode effect analysis (FMEA)*, AIP Conference, aip.scitation.org.
- Ş Paul, A Costea,(2017), *Independent thermal protection for electrical circuit breaker panels, electrical power cables and lines. A practical solution proposal*, - 2017 9th International Conference on ..., 2017 - ieeexplore.ieee.org
- T Daszczyński, W Chmielak, (2020), *Basic Concept of MV Circuit Breaker Fault Detection by Image Processing ... - 2020 Progress in ...*, 2020 - ieeexplore.ieee.org
- M Hrabčík, R Goňo, S Rusek, (2014), *Thermovision in distribution power networks*, - Przeglad Elektrotechniczny,
- JE Smith, G Paoletti, I Blokhintsev, (2004), *Hot-spot hunting*, IEEE Industry Applications ..., 2004 - ieeexplore.ieee.org
- D Siegel, M Anheuser, (2014), *Significance of resistances of switching contacts for the temperature rise of LV circuit breakers*, International Conference on Electrical, - ieeexplore.ieee.org
- EPA Van Lanen, M Popov, (2005), *Vacuum circuit breaker current-zero phenomena*, Plasma Science, 2005 - ieeexplore.ieee.org
- MT Kesim, H Yu, Y Sun, M Aindow, SP Alpay, (2018), *Corrosion, oxidation, erosion and performance of Ag/W-based circuit breaker contacts: A review*, - Corrosion Science, 2018 - Elsevier
- Pedro J. Zarco-Periñán, José L. Martínez-Ramos, Fco. Javier Zarco-Soto, (2021), *A novel method to correct temperature problems revealed by infrared thermography in electrical substations*, Infrared Physics & Technology, Vol. 113, March 2021, 103623, <https://doi.org/10.1016/j.infrared.2020.103623>



● **8% Overall Similarity**

Top sources found in the following databases:

- 6% Internet database
- Crossref database
- 4% Submitted Works database
- 5% Publications database
- Crossref Posted Content database

TOP SOURCES

The sources with the highest number of matches within the submission. Overlapping sources will not be displayed.

1	<b>ojs.unimal.ac.id</b> Internet	2%
2	<b>repo.bunghatta.ac.id</b> Internet	1%
3	<b>es.scribd.com</b> Internet	<1%
4	<b>Universitas Katolik Widya Mandala on 2021-05-24</b> Submitted works	<1%
5	<b>mdpi.com</b> Internet	<1%
6	<b>Naufal Hajjaj Noor Hashim, Nor Azuana Ramli. "Smart Building Energy ...</b> Crossref	<1%
7	<b>Rochester Institute of Technology on 2012-03-30</b> Submitted works	<1%
8	<b>ideas.repec.org</b> Internet	<1%

9	<b>mse.engr.uconn.edu</b> Internet	<1%
10	<b>transport.nsw.gov.au</b> Internet	<1%
11	<b>Pedro J. Zarco-Periñán, José L. Martínez-Ramos. "Influencial factors i...</b> Crossref	<1%
12	<b>"Table of Contents", 2022 Power System and Green Energy Conference...</b> Crossref	<1%
13	<b>researchgate.net</b> Internet	<1%