

THE EFFECT OF EXPORT AND IMPORT ON INFLATION IN INDONESIA PERIOD 1990-2016

Nurul Ulfa^{a*}, Tarmizi Abbas^{b*}

* Faculty of Economics and Business, Malikussaleh University

aCorresponding author: nurululfaekp@gmail.com

b tarmiziabbas@unimal.ac.id

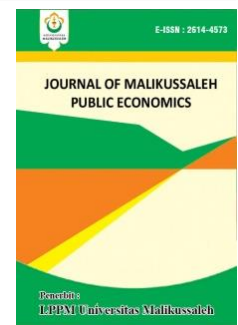

ARTICLE INFORMATION ABSTRACT

Keywords:

Exports, Imports and Inflation.

This research conducts to determine the effect of exports and imports on inflation in Indonesia in the period 1990-2016. The data used in this study are time series in the periode 1990-2016 obtained from the BPS Indonesia and Bank Indonesia. Data are then analyzed by using multiple linear regression. The results showed that exports did not affect inflation. Imports have a significant and positive effect on inflation in Indonesia in the period 1990-2016.

1. INTRODUCTION

Macro economics describes changes that occur and can affect companies and society. Even though macro economics is still relatively young and imperfect, but it can be used to analyze the best way to influence government policy targets, such as economic growth, price stability or inflation, labor and achieving a sustainable balance of payments (Prasetyo, 2009).

Table 1

The amount of Indonesia's exports in 2012-2016

Number	Year	Eksport (USD)	Import (USD)	Inflation (%)
1	2012	190.020,3	191.689,5	4,30
2	2013	182.551,8	186.628,7	8,38
3	2014	175.980,0	178.178,8	8,36
4	2015	150.366,3	142.694,8	3,35
5	2016	145.186,2	135,652,8	3,02

Source: BPS Indonesia, 2017

Based on Table 1 above, it can be seen that the value of exports in Indonesia has decreased since 2012-2016, while the import value has also decreased. The highest import value occurred in 2012, while imports reached the lowest point of 135,652.8 in the year 2016. Likewise with inflation, the inflation rate reaches the highest in 2013, as amounted 8,38%.

The problem occurs when the export value is high, but does not reduce inflation, so also when high imports do not cause an increase in inflation. In fact, according to the theory, when domestic goods have a surplus to be exported, the price of goods in the country should be low.

This when the export value is high, the inflation rate will be lower. Indonesian exports of in 2013 are higher than in 2014, but the inflation conditions actually experience the highest point. The same condition happens with the imports of Indonesia when the value of import is high, inflation tended to be lower.

The goals of in this study are 1). Knowing the effect of export on inflation in Indonesia for the period 1990-2016. 2). Knowing the effect of imports on inflation in Indonesia in the period 1990-2016.

2. THEORITICAL REVIEW

Definition of Inflation

Inflation is the tendency of prices to rise in general and continuously (Sukirno, 2002).

Definition of Exports

Exports are one of the economic sectors that play an important role through market expansion between several countries (Baldwin, 2005).

Conceptual Framework

Based on the description of the literature review above, the conceptual framework in this study can be explained as follows.

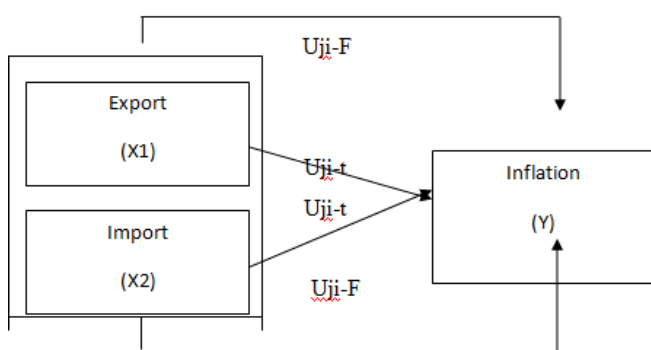

Figure 1
Conceptual Framework

Based on Figure 1 above, it can be seen that this study uses an independent variables exports and imports, while inflation is the dependent variable. These variables are tested partially using the t-test and simultaneous using the F-test.

Research Hypothesis

Based on the formulation of the problem that has been written in the previous part, the hypothesis in this study are:

H1: Exports have a negatif and significant effect on inflation in Indonesia in the period 1990-2016.

H2: Imports have a positive and significant effect on inflation in Indonesia in the period 1990-2016.

3. RESEARCH METHODS

The study uses data on inflation, exports and imports of Indonesia in the years 1990-2016. The data is obtained from the Indonesian Central Bureau of Statistics (BPS).

Definition of Operational Variables

1. Inflation (Y)
The is rate of increase in the price of goods in Indonesia, measured in units of percent (%).
2. Export (X1)
The value of exports in Indonesia, measured in USD.
3. Import (X2).
The value of imports in Indonesia, measured in USD.

Data Analysis Methods

The data processes using a percentage formula which is useful to see trends of each indicator. Furthermore, to find out whether there is a significant effect of the independent variables on the dependent variable, multiple linear regression models are used. The formula is as follows:

$$Y = \alpha + \beta_1 X_1 + \beta_2 X_2 + e$$

Y = inflation

X1 = Export

X2 = Import

α = constant

β_1, β_2 = Coefficient Regression

e = standard error

Because the variables used do not have the same units, they are converted in the form of semi-logarithms. The data analysis formula is as follows:

$$Y = a + \text{Log } b_1 X_1 + \text{Log } b_2 X_2 + e_i$$

4. RESULTS AND DISCUSSIONS

Multiple Linear Regression

The data analysis used in this study is quantitative analysis with a multiple linear regression equation. Quantitative analysis is an analysis used to analyze data that require statistical calculations, so this analysis is often referred to as statistical analysis.

Table 2
Results of Multiple Linear
Regression Analysis

Dependent Variable: INFLASI

Method: Least Squares

Sample: 1990 2016

Included observations: 27

Variable	Coefficient	Std. Error	t-Statistic	Prob.
C	1.028326	1.753878	0.586316	0.5631
LOG(EKSPOR)	-0.008885	0.007030	-1.263788	0.2184
LOG(IMPOR)	0.884304	0.153222	5.771379	0.0000
R-squared	0.623647	Mean dependent var		10.95032
Adjusted R-squared	0.592284	S.D. dependent var		0.763128
S.E. of regression	0.487277	Akaike info criterion		1.504471
Sum squared resid	5.698533	Schwarz criterion		1.648453
Log likelihood	-17.31036	Hannan-Quinn criter.		1.547285
F-statistic	19.88497	Durbin-Watson stat		0.906031
Prob(F-statistic)	0.000008			

Source: Data processed, 2018

The results of calculations using the regression method can be seen in the following equation:

$$Y = 1.028326 - 0.008885 \text{ LOG (Export)} + 0.884304 \text{ LOG (Import)}$$

The formulation of the model above shows that the value of the constant variable is 1.028326, which means that if exports and imports are 0, then the inflation is 1.02%

Export coefficient value is 0.008885 which means that if exports increase by 1%, inflation will decrease by 0.08% per year.

The coefficient value of the import variable is 0.884304, which means that if imports increase by 1%, inflation will increase by 0.88%.

The Adjusted R Square value in table 2 is 0.592284 or 59.22%. This means that the independent variables, namely exports and imports can explain the dependent variable which is inflation of 59.22%, while the remaining 40.78% is explained by other variables.

Classical assumption test

Classical assumption test individually analyzes the variables set out above to see the real effect on the inflation for the classic assumption test this study is conducted with a normality test.

Autocorrelation Test

There are several ways that can be used to detect the presence or absence of autocorrelation. One of them is LM-Test. Here are the results of data processing to detect autocorrelation:

Table 3
Autocorrelation Test of LM
Test Method

Breusch-Godfrey Serial Correlation LM Test:

F-statistic	0.404796	Prob. F(2,22)	0.6720
Obs*R-squared	0.958325	Prob. Chi-Square(2)	0.6193

Test Equation:

Dependent Variable: RESID

Method: Least Squares

Date: 09/12/18 Time: 02:50

Sample: 1990 2016

Included observations: 27

Presample missing value lagged residuals set to zero.

Source: Data processed, 2018

Based on Table 3 above, it can be explained that the LM Test value through Obs * R-squared is 0.958325 with Prob. Chi-Square of 0.6193 is greater than 0.05. Thus it can be concluded that there is no autocorrelation in this study.

Multicollinearity Test

Multicollinearity is a very strong relationship between explanatory variables in the regression model. Multicollinearity causes the resulting estimation to be incorrect. Based on Gujarati (2003; 359) this multicollinearity can be detected by: First, a statistically high F value, and no or only are significant variables of t-test. Second, the correlation matrix coefficient between variables is high (> 0.8). If the above is found, (Manurung, et al, 2005: Kuncoro, 2004).

To detect multicollinearity can be looking at the correlation between independent variables. If the correlation between independent variables is less than 0.8, it can be said that there is no multicollinearity.

Table 4
Multicollinearity Test Results

	EKSPOR	IMPOR	INFLASI
EKSPOR	1	0.7447462411688299	-0.2083302560564264
IMPOR	0.7447462411688299	1	-0.2538291481002606
INFLASI	-0.2083302560564264	-0.2538291481002606	1

Source: Data Processed, 2018

In table 4 above shows that in the regression model there is no multicollinearity. This is evidenced by the above correlation values smaller than 0.8.

Heteroscedasticity Test

A study is said to have a heteroscedasticity problem if the error value or residual model observed does not have a constant variant of one observation to the other observation. The results of heteroscedasticity tests based on the Breusch-Pagan-Godfrey test can be seen in the following table:

Table 5
Heteroscedasticity Test

Heteroskedasticity Test: Breusch-Pagan-Godfrey

F-statistic	0.497827	Prob. F(2,24)	0.6140
Obs*R-squared	1.075493	Prob. Chi-Square(2)	0.5841
Scaled explained SS	8.373678	Prob. Chi-Square(2)	0.0152

Test Equation:

Dependent Variable: RESID^2

Method: Least Squares

Date: 09/12/18 Time: 02:53

Sample: 1990 2016

Included observations: 27

Variable	Coefficient t	Std. Error	t-Statistic	Prob.
C	403.8592	294.8269	1.369818	0.1834
EKSPOR	-0.000850	0.003737	-0.227399	0.8220
IMPOR	-0.001905	0.003976	-0.479018	0.6363

R-squared	0.039833	Mean dependent var	174.0978
Adjusted R-squared	-0.040181	S.D. dependent var	787.6086
S.E. of regression	803.2761	Akaike info criterion	16.31971
Sum squared resid	15486061	Schwarz criterion	16.46370
Log likelihood	-217.3161	Hannan-Quinn criter.	16.36253
F-statistic	0.497827	Durbin-Watson stat	2.097612
Prob(F-statistic)	0.613990		

Source: Data Processed, 2018

Based on table 5 above, we can see that the Obs * R-square probability value is 1.075493 compared to the level of significance. If the probability of significance is above 0.05 or 0.5841, it can be concluded that there is no heteroscedasticity.

Hypothesis testing

T Test

The t test is used to see the significance of the effect of individual independent variables on the dependent variable by assuming that other variables are constant. This test is done by comparing t count to t table (Sulaiman, 2004).

From the results of the partial test calculation between exports and inflation, the calculated t value is -1.263788, and ttable is 1.717 or -1.263788 < 1,717 or significance (0.2184 > 0.05). The tcount is smaller than t table, it can be concluded that exports have no effect on inflation so the proposed hypothesis is rejected.

From the results of the partial test calculation between imports and inflation, the value of t count is 5.771379, and ttable is 1.717 or 5.771379 > 1.717). The tcount is greater than t table, it can be concluded that imports have a positive and significant effect on inflation so the proposed hypothesis is accepted as the truth.

F Test

The F test is conducted to see the effect of the overall independent variables on the dependent variable. Testing is done by comparing the value of F count with Ftable. (Sulaiman, 2004). Based on probability values. If the significance value is smaller than 0.05 or 5%, the proposed hypothesis is accepted or said to be significant. If the significance value is greater than 0.05 or 5%, the proposed hypothesis is rejected or not significant.

Based on Table 4 above, it can be seen that the results of the F test show the F value of 19.88497 with a significance of 0.00008. The significance value is smaller than 0.05 so that it can be concluded that the independent variables, namely exports and imports simultaneously have a significant effect on inflation so that the proposed hypothesis is accepted the truth.

Discussion

Effect of Export on Inflation

Based on the results of statistical testing, exports did not significantly influence inflation in Indonesia in the 1990-2016 period. No effect of exports on inflation is due to the increase in domestic prices of goods, the appreciating of the

value the rupiah exchange rate and availability of goods at the level of traders and distributors. In addition, the value of Indonesian exports on average during that period is higher than the value of imports. The results of this study support previous research by Silvia, Wardi, and Aimon (2013) which states that Indonesian exports have no significant effect on inflation.

Effects of Imports on Inflation

Based on the results of the study, it is known that imports affect inflation in Indonesia. High import policy indicates that there is no or less availability of goods needed at the domestic level, this will cause a surge in the price of goods due to increased demand. The results of this study support previous research by and Aimon (2013) which states that Indonesian imports have a significant effect on inflation.

5. CONCLUSIONS AND SUGGESTION

Conclusion

Based on the result of the above research, some conclusions can be drawn as follows:

1. Exports do not effect inflation in Indonesian in the year 1990-2016.
2. Imports significantly and positively effect to inflation in Indonesia in the year 1990-2016.

Suggestion

1. Further research is expected to be able to use a longer research period with the aim of getting better results. In addition, the next research is expected to be able to add other independent variables besides the independent variables that have existed in this study.
2. Based on the research and discussion that has been conducted, the government needs to be careful in importing more than the export value because the increase in imports will have a proportional influence on the increase in inflation in Indonesia.

REFERENCES

- Baldwin. (2005). *Pengantar Ekonomi Industri: Pendekatan struktur, Perilaku dan Kinerja Pasar*. Yogyakarta: BPF E Anggota IKAPI.
- Prasetyo, P. E. (2009). *Perilaku dan Strategi Bersaing Agroindustri: Pendekatan... Game Theory*. *Media Ekonomi Dan Manajemen, Vol. 20. U*.
- Sukirno. (2002). *Ekonomi Pembangunan dan Perencanaan*. Jakarta: PT Raja Grafindo Persada